

# Chill-Pak<sup>™</sup> **COLD DRAFT ARMS** Draft Systems *with Faucets*

## MODEL NUMBERS:

### Stainless

- CT17S-1F**, Stainless steel cold draft arm – 1 Faucet
- CT17S-2F**, Stainless steel cold draft arm – 2 Faucets
- CT17S-3F**, Stainless steel cold draft arm – 3 Faucets

### Brass

- CT17B-1F**, Brass cold draft arm – 1 Faucet
- CT17B-2F**, Stainless steel cold draft arm – 2 Faucets
- CT17B-3F**, Stainless steel cold draft arm – 3 Faucets

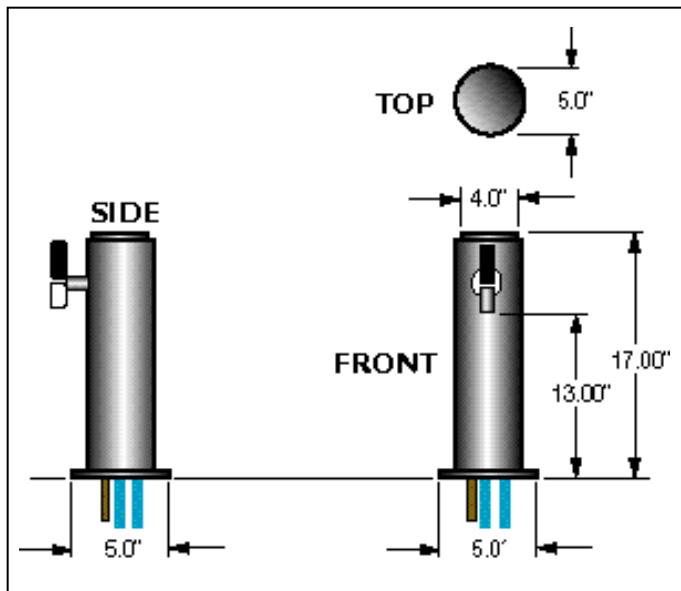

## CHILL-PAK<sup>™</sup> COLD DRAFT ARMS with FAUCETS:

Custom draft towers designed for flush mount directly on the bar surface. Draft arms are 4.00" O.D. diameter, with 1.00" wide mounting flange, faucets (faucet handles not included). Includes integrated aluminum cast cold plate to assure maximum efficiency in keeping beer cold. Glycol flows through the cold plate acting as a heat exchanger. Minimum 1.00" internal insulation to prevent loss of temperature. 3/8" barbed fittings for beer lines, 1/2" barbed fittings for Glycol lines.

## SPECIFICATIONS:

- 4.00" diameter brass or stainless steel column
- 3/8" barbed beer fittings
- 1/2" barbed Glycol fittings
- Minimum opening for mounting: 3.00"
- Maximum opening for mounting: 3.75"



**MAKE THE RIGHT CALL: 1-888-732-2446**

**McCall Refrigeration**  
81 West Holly Street, Parsons, TN 38363  
Phone: 901.847.5570 • Fax: 901.847.9012  
Website: [www.4mccall.com](http://www.4mccall.com)

*specifications subject to change without notice.*  
©1999 Chill-Pak 99-005-8/99